

C I M E N T O®
C O L L E C T I O N

PRODUCTS LIST INDICE

MURANO Omri Revesz	08-13
<i>Tavolini Coffee Tables</i>	
VIGNOLE Parisotto + Formenton	14-21
<i>Tavolini Coffee Tables</i>	
BURANO Defne Koz & Marco Susani	22-27
<i>Sedia a dondolo Rocking chair</i>	
TORCELLO Defne Koz & Marco Susani	28-39
<i>Sedute Chairs & Bench</i>	
LIDO Parisotto + Formenton	40-49
<i>Panca Bench</i>	
TRONCHETTO Parisotto + Formenton	50-61
<i>Seduta & Tavolino Stool & Coffee Table</i>	
ZITELLA Parisotto + Formenton	62-79
<i>Seduta & Tavolino Stool & Coffee Table</i>	
ACCADEMIA Studio 63	80-97
<i>Contenitori, tavolo & complementi Storage, table & complements</i>	
GIUDECCA Parisotto + Formenton	98-103
<i>Tavolo Table</i>	
ILLUSTRATED GUIDE Cimento Collection	104-120
MATERIALI Materials	
DESIGNERS Cimento Collection	121-130

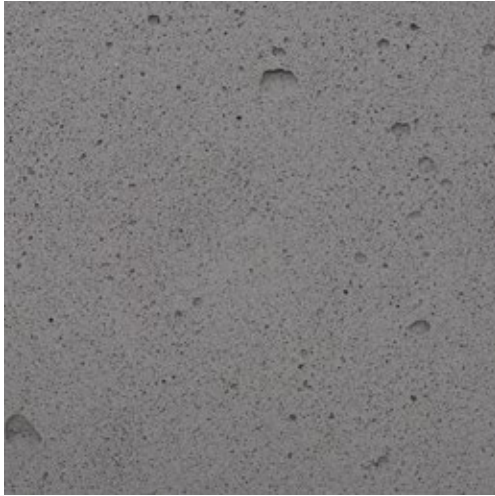



C I M E N T O W I L L

Una collezione di arredi scultorei, per interni ed esterni, nata sotto l'art direction di Aldo Parisotto, Parisotto + Formenton Architetti. Tavoli, coffee table, sedute e complementi dalla spiccata matericità, possenti e leggeri al tempo stesso, realizzati in **CIMENTO®**: un composto cementizio esclusivo registrato, che impiega per oltre il 90% aggregati minerali mescolati ad un legante cementizio.

*A collection of sculptural furniture, for indoor & outdoor use, born under the art direction of Aldo Parisotto, of Parisotto + Formenton Architetti. Tables, coffee tables, stools, benches, storage systems and complements are well recognizable for their strong personality, the tactile feeling having a solid look with a light soul. All elements are realized in **CIMENTO®**: an exclusive material registered, which uses over 90% mineral aggregates mixed with a cement binder.*





BURANO sedia a dondolo small & medium rocking chair small & medium |
TORCELLO sedia, poltrona lounge & panca chair, lounge chair & bench —

MURANO

TAVOLINI *COFFEE TABLES*

DESIGN

OMRI REVESZ





MURANO tavolini alto & basso tall & low coffee table |
 MURANO tavolino alto tall coffee table —

I tavolini Murano sono il risultato della combinazione di due volumi semplici e sovrapposti, uniti per creare un oggetto bilanciato tra scultura e funzione. Le forme e i colori si ispirano ai calici e ai vetri colorati tipici dell'arte vetraria muranese.

Giocando con altezze e diametri diversi, i coffee table Murano si prestano a molteplici usi ed applicazioni.

Murano tables are the result of the combination of two simple and overlapping volumes, united to create a balanced object between sculpture and function. The shapes and colors are inspired by the glass goblets and colored glasses typical of Murano's glassmaking art.

Playing with different heights and diameters, Murano coffee tables can be used in numerous ways and settings.





MURANO tavolini alto & basso tall & low coffee table |

| MURANO tavolini alto & basso tall & low coffee table



VIGNOLE

TAVOLINI *COFFEE TABLES*

DESIGN

PARISOTTO + FORMENTON





VIGNOLE tavolino rettangolare rectangular coffee table |

VIGNOLE tavolino rettangolare & quadrato rectangular & square coffee table —

Forme naturali e morbide che ricordano ciottoli o piccoli atolli. Questi oggetti sembrano levigati dal tempo e si presentano con un aspetto "soft" che dialoga con la tattilità morbida della superficie, arricchito dal contrasto di cromie: il piano dei tavolini e il cuore - eccentrico - sono a volte in nuance tono su tono, altre in contrasto più netto.

La collezione di tavolini Vignole si compone di quattro elementi al contempo omogenei ed eterogenei per altezza, forma e colore, perfetti per impreziosire e dare unicità agli ambienti.

Natural and soft shapes remind of pebbles or small atolls. These objects seem to be smoothed by time and present themselves with a "soft" appearance that dialogues with the delicate tactility of the surface, enriched by the contrast of colors: the table top and the - eccentric - heart can be in contrast or in graduated nuances.

The Vignole coffee table collection consists of four elements that are at the same time homogeneous and heterogeneous in height, shape and color, and it is perfect for decorating and giving uniqueness to any environment.







VIGNOLE *tavolino circolare* round coffee table |
VIGNOLE *tavolino circolare* round coffee table —





VIGNOLE tavolino circolare round coffee table |

VIGNOLE tavolino rettangolare & quadrato rectangular & square coffee table —

BURANO

SEDIA A DONDOLO *ROCKING CHAIR*

DESIGN

DEFNE KOZ & MARCO SUSANI





BURANO sedia a dondolo small & medium small & medium rocking chair |
BURANO sedia a dondolo small & medium small & medium rocking chair —
TRONCHETTO sgabello stool

Burano è una poltroncina a dondolo che combina con ironia la forma solida e massiccia con l'equilibrio instabile del dondolo. Disponibile in diversi colori e nella versione pensata per i più piccoli.

Divertente, orgogliosamente solida ma allo stesso tempo leggera. È perfetta per ondeggiare e farsi cullare mentre si legge un libro o si ascolta della buona musica, in salotto o nella zona living.

Burano is a rocking chair that ironically combines its solid and massive shape with the unstable balance of the rocking chair. It is available in different colors and in a smaller version designed for kids.

Funny, proudly solid, but light at the same time, it is perfect for swinging and rocking while reading a book or listening to good music, in the sitting or living room.







BURANO sedia a dondolo small & medium small & medium rocking chair |
BURANO sedia a dondolo small & medium small & medium rocking chair —

TORCELLO

SEDUTE *CHAIRS & BENCH*

DESIGN

DEFNE KOZ & MARCO SUSANI







TORCELLO sedia, poltrona lounge & panca chair, lounge chair & bench |
 TORCELLO sedia chair TRONCHETTO sgabello stool ACCADEMIA libreria bookcase —

Una famiglia di sedute accomunate da un linguaggio iconico. Torcello si ispira alla forma familiare delle panchine in cemento, con un contrasto tra le proporzioni massicce, che danno un positivo senso di solidità, e la leggerezza della costruzione.

La panca Torcello ben si adatta all'arredo di diversi ambienti pubblici o privati. Realizzata in **CIMENTO®**, è disponibile in un'ampia gamma di cromie.

A family of seats joined by an iconic language. Torcello is inspired by the familiar shape of the concrete benches, with a contrast between its massive proportions, which give a positive sense of solidity, and the lightness of the construction.

*The Torcello bench is well suited to different public or private environments. Made of **CIMENTO®**, it is available in a wide range of colors.*







TORCELLO sedia chair ZITELLA sgabello stool |
TORCELLO poltrona lounge lounge chair —



TORCELLO poltrona lounge lounge chair — |





TORCELLO panca bench — |







TORCELLO seduta & panca chair & bench |
ZITELLE sgabello stool
TRONCHETTO sgabello stool
ACCADEMIA libreria bookcase

LIDO

PANCA *BENCH*

DESIGN

PARISOTTO + FORMENTON







LIDO panca bench — |



archiproducts®
DESIGN AWARDS
—
WINNER 2019

Fortemente innovativa, la panca Lido con la sua forma dalla forte, marcata identità, conferma il linguaggio inedito ed originale del progetto che la rende una scultura dinamica e armonica, capace di adattarsi agli ambienti più diversi. La seduta e lo schienale, leggeri e snelli, sono delicatamente sorretti dai torniti supporti in un equilibrio estetico e formale tra spessori minimi, forme piene, superfici tattili in **CIMENTO®**.

*Deeply innovative, Lido bench with its strong identity, confirms the new language and the originality of the project that makes it dynamic and harmonic and able to suit any environment. The light and slender seat and backrest are gently supported by the turned supports, getting an aesthetic and formal balance between minimum thicknesses, full shapes, and tactile surfaces in **CIMENTO®**.*







LIDO panca bench — |





LIDO panca bench — |





TRONCHETTO

SGABELLO *STOOL*

DESIGN

PARISOTTO + FORMENTON







Monolitici e scultorei, i volumi puri sovrapposti della base e del corpo principale creano una totemica presenza dalle linee essenziali che dialoga con la delicata irregolarità della superficie in **CIMENTO®**.

Versatili e flessibili, le sedute Tronchetto, possono inserirsi con facilità in ambienti differenti, conferire dinamismo agli spazi o essere posti a contrasto con lo stile circostante. Adatte sia in ambito domestico che contract.

*Monolithic and sculptural, the pure juxtaposed volumes of the base and of the body create a totemic presence made of essential lines which dialogue with the delicate irregularity of the surface made in **CIMENTO®**.*

Versatile and flexible, Tronchetto stools are able to fit easily in different environments, to give dynamism to contemporary spaces or play in contrast with classic surroundings. Suitable for both domestic and commercial field.

TRONCHETTO sgabello stool — |





TRONCHETTO sgabello stool



| TRONCHETTO sgabello stool ZITELLA sgabello stool

TRONCHETTO

TAVOLINO *COFFEE TABLE*

DESIGN

PARISOTTO + FORMENTON



CIMENTO®
COLLECTION



TRONCHETTO tavolino coffee table ZITELLA sgabello stool |
 TRONCHETTO tavolino coffee table & sgabello stool —

La forza espressiva del **CIMENTO®** unita alla leggerezza e all'eleganza sobria delle forme fanno di questi complementi d'arredo dei pezzi senza tempo, capaci di donare personalità e carattere agli spazi in&out door. Linee pulite ed essenziali, dai profili netti e i volumi generosi, contraddistinguono i coffee table della collezione.

*The expressive power of **CIMENTO®** together with the lightness and the sober elegance of the forms make those furnishing complements timeless pieces, able to give personality and character to in&outdoor spaces. Clean and essential lines, strong profiles and generous volumes are the distinguishing connotations of the coffee tables of this collection.*







TRONCHETTO tavolino coffee table & sgabello stool |
TRONCHETTO tavolino coffee table ZITELLA sgabello stool —

ZITELLA

SGABELLO *STOOL*

DESIGN

PARISOTTO + FORMENTON







ZITELLA sgabello stool — |

Monoliti dalle forme plastiche e arrotondate di forte presenza, declinano nella tridimensionalità la caratteristica matericità di **CIMENTO®**.

Le sedute Zitella sono complementi per soluzioni d'arredo all'insegna della flessibilità, adatti a completare con originalità l'interior di uno spazio classico o contemporaneo.

*These monoliths with rounded and flexible shapes have a strong presence, able to transform into three-dimensionality the characteristic materiality of **CIMENTO®**.*

The Zitella seats are complements for flexible furnishing solutions, suitable to complete the interior of a space with originality.





| ZITELLA sgabello stool









I ZITELLA sgabello stool



| ZITELLA sgabello stool

V

VI



VII

VIII



ZITELLA

TAVOLINO *COFFEE TABLE*

DESIGN

PARISOTTO + FORMENTON





ZITELLA tavolino coffee table — |

Monoliti dalle forme plastiche e arrotondate di forte presenza, declinano nella tridimensionalità la caratteristica matericità di **CIMENTO®**.

Il tavolino Zitella è un complemento per soluzioni d'arredo all'insegna della flessibilità, adatto a completare con originalità l'interior di uno spazio classico o contemporaneo.

*These monoliths with rounded shapes and flexible shapes have a strong presence, able to transform into three-dimensionality the characteristic materiality of **CIMENTO®**.*

The Zitella coffee table is a complement for flexible furnishing solutions, suitable to complete the interior of a space with originality.





| ZITELLA tavolino & sgabello coffee table & stool



| ZITELLA tavolino & sgabello *coffee table & stool*

ACCADÉMIA

CONTENITORI *STORAGE SYSTEMS*
TAVOLO & *TABLE &*
COMPLEMENTI *COMPLEMENTS*

DESIGN
STUDIO 63

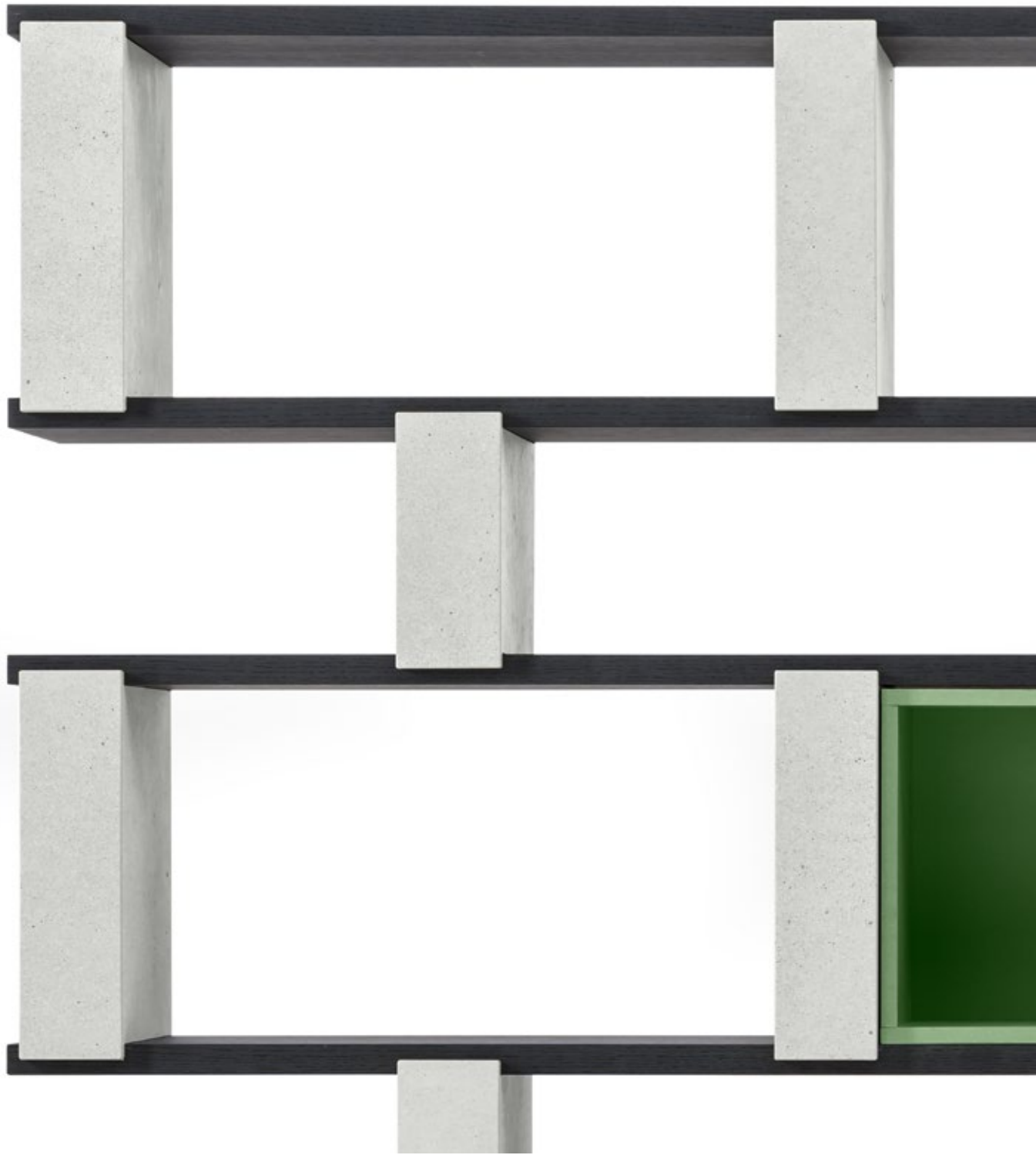



ACCADEMIA contenitori storage system — |

I contenitori Accademia (auto-portanti o a muro) si distinguono per l'equilibrio estetico e formale dato dalla simmetria, dall'alternanza di pieni e vuoti, dai differenti spessori di elementi orizzontali e verticali, dall'unione di due materiali contrapposti, **CIMENTO®** e legno.

Contenitori dal forte impatto visivo, modulari, personalizzabili in altezza, larghezza e profondità, conferiscono personalità e pienezza a differenti spazi, dal residenziale agli uffici agli showroom.

*Accademia storage systems (self-supporting or wall-mounted) stand out for their aesthetic and formal balance given by symmetry, by the alternation of full and empty spaces, by the different thicknesses of horizontal and vertical elements, by the combination of two contrasted materials, **CIMENTO®** and wood.*

Storage systems with strong visual impact, modular, customizable in height, width and depth, they can give personality and fullness to different environments, from residential to offices to showrooms.









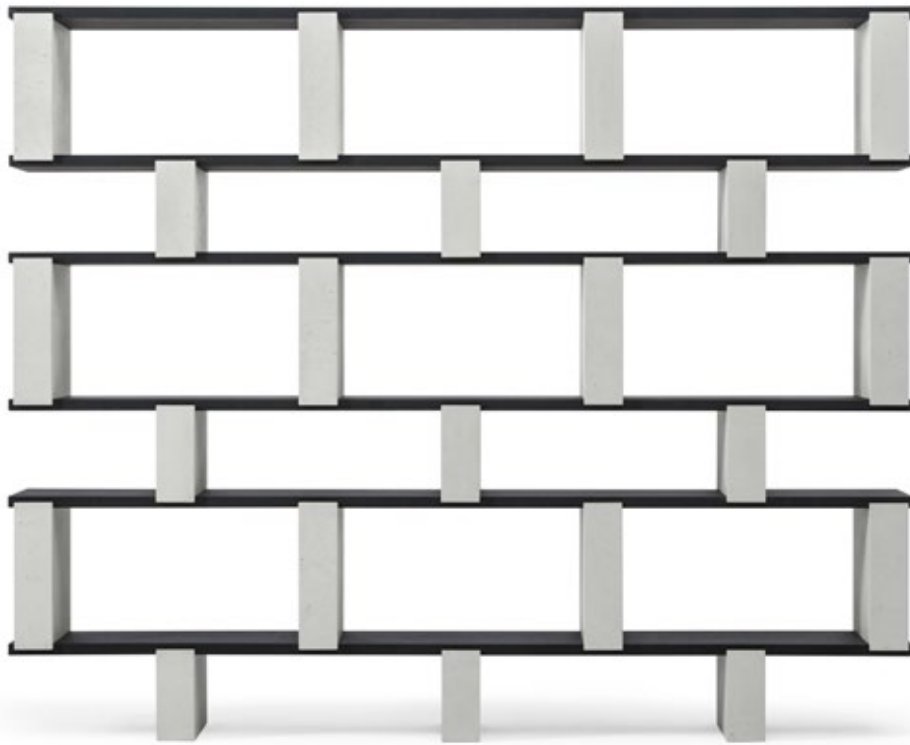

TORCELLO panca bench ACCADEMIA contenitori storage system |
ACCADEMIA contenitori storage system —





| ACCADEMIA contenitori e accessori storage system with accessories



ACCADEMIA contenitori e accessori storage system with accessories ZITELLA sgabello stool |



| ACCADEMIA contenitori e accessori & tavolo storage system with accessories & table

ACCADÉMIA

TAVOLO *TABLE*

DESIGN

STUDIO 63





ACCADEMIA tavolo table |
ACCADEMIA tavolo table ZITELLA sgabello stool —

Linee pulite e materiali naturali per un tavolo che invita alla convivialità: i tradizionali piani di appoggio formati da mattoni e assi di legno sono reinterpretati in chiave contemporanea attraverso la combinazione di gambe in **CIMENTO®** e top in essenza.

I tavoli Accademia, molto più di semplici complementi d'arredo, sono funzionali e versatili e conferiscono carattere sia agli ambienti domestici che agli spazi office.

*Linear outlines and natural materials for a table that invites conviviality: the traditional support surfaces made of bricks and wooden boards are reinterpreted in a contemporary key through the combination of legs in **CIMENTO®** and top in essence.*

Accademia tables, much more than simple furnishing accessories, are functional and versatile and give character to both home and office spaces.







ZITELLA sgabello stool |
ACCADEMIA libreria bookcase
ACCADEMIA tavolo table

GIUDECCA

TAVOLO *TABLE*

DESIGN

PARISOTTO + FORMENTON







GIUDECCA tavolo table — |

Famiglia di tavoli da pranzo: il sottile piano, rotondo o quadrato, si combina con il basamento scultoreo composto da un fascio di quattro elementi pieni e bombati, esaltando al massimo tutte le connotazioni estetiche del **CIMENTO®**, sia nell'uso su superficie sia nella tridimensionalità.

*This family of dining tables is characterized by the thin top, round or squared, combined with the sculptural base composed of four full rounded elements, enhancing all the aesthetic connotations of the **CIMENTO®**, both in its surface and in three-dimensional use.*

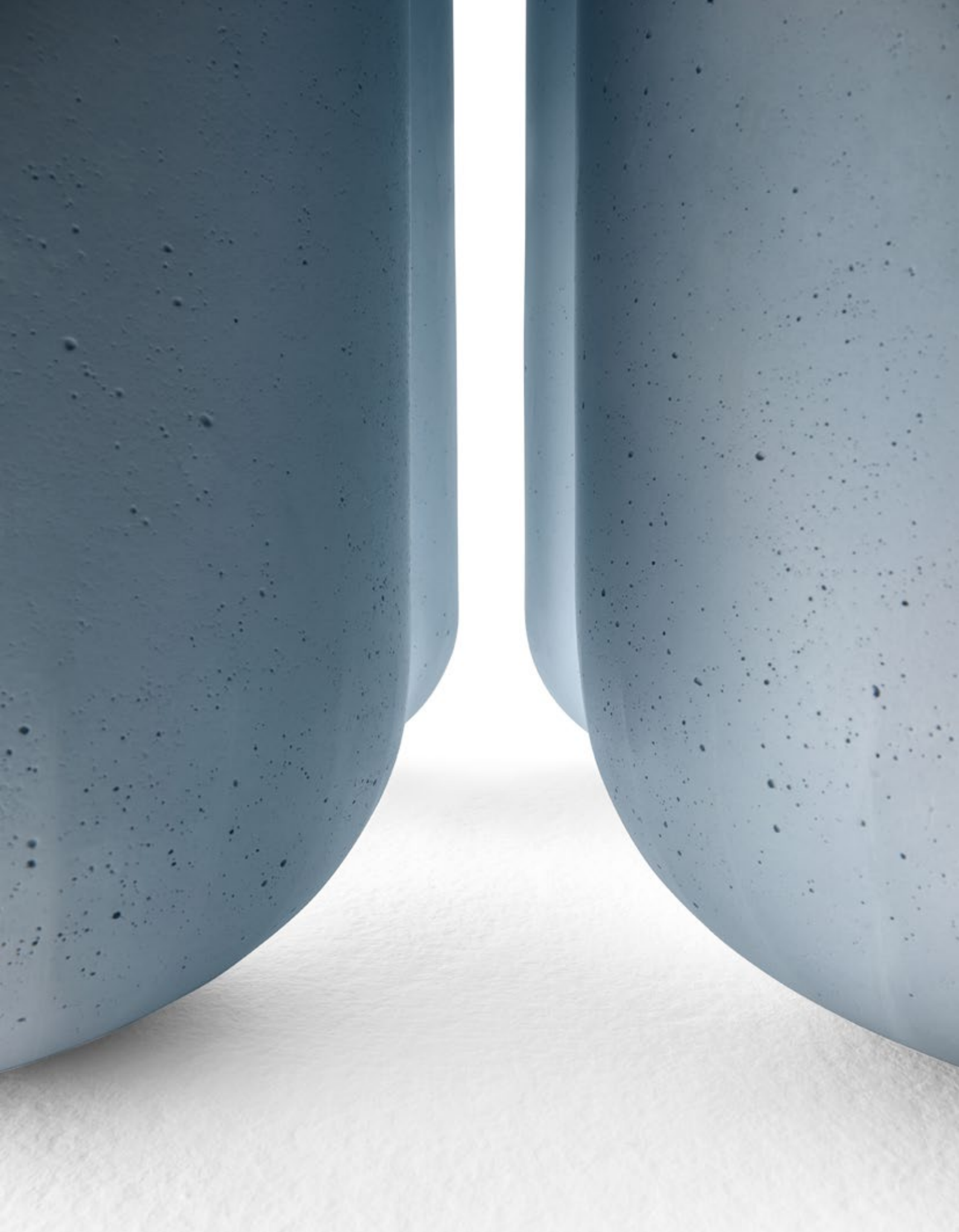



ZITELLA sgabello stool GIUDECCA tavolo table |

| ZITELLA sgabello stool | GIUDECCA tavolo table



ILLUSTRATED GUIDE

CIMENTO COLLECTION

ILLUSTRATED GUIDE

CIMENTO

MURANO Omri Reve

P. 08-13

Tavolino *Coffee Table*

Coffee table in **CIMENTO®**. Disponibile in diverse colorazioni.
Coffee table in CIMENTO®. Available in different colors.

CMUCT01|____ **T**

Dimensions in cm: L. 600 | D. 600 | H. 600
 Net weight: 17 Kg



600

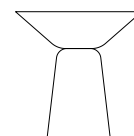
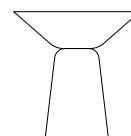
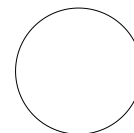

600

Tavolino *Coffee Table*

Coffee table in **CIMENTO®**. Disponibile in diverse colorazioni.
Coffee table in CIMENTO®. Available in different colors.

CMUCT02|____ **T**

Dimensions in cm: L. 700 | D. 700 | H. 400
 Net weight: 24 Kg



700

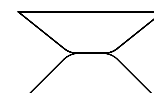
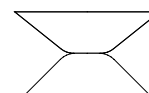
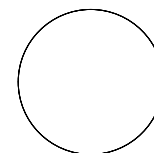

400

VIGNOLE Parisotto + Formenton

P. 14-21

Tavolino *Coffee Table*

Coffee table policromi in **CIMENTO®**.
Polychromatic coffee table in CIMENTO®.

CVICT01|___|___ **T**

Dimensions in cm: L. 540 | D. 540 | H. 314
Net weight: 17 Kg

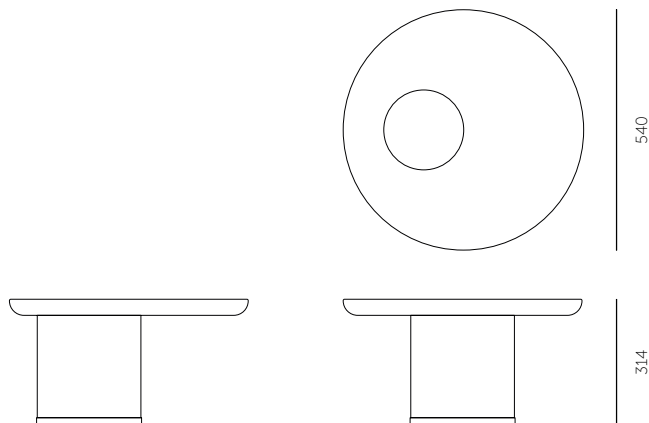

Tavolino *Coffee Table*

Coffee table policromi in **CIMENTO®**.
Polychromatic coffee table in CIMENTO®.

CVICT02|___|___ **T**

Dimensions in cm: L. 720 | D. 720 | H. 364
Net weight: 20 Kg

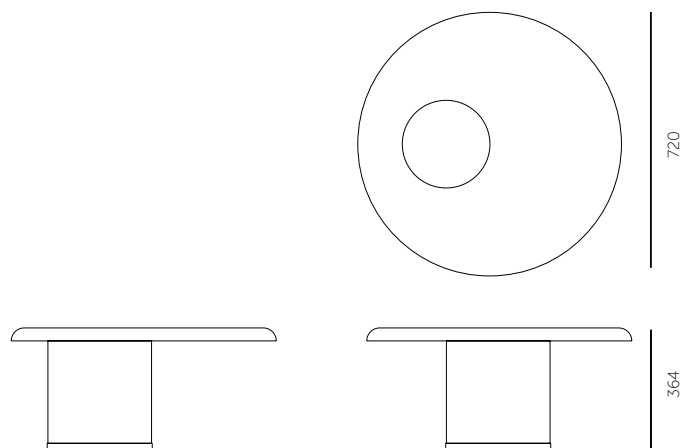

ILLUSTRATED GUIDE

CIMENTO

VIGNOLE Parisotto + Formenton

P. 14-21

Tavolino *Coffee Table*

Coffee table policromi in **CIMENTO®**.
Polychromatic coffee table in CIMENTO®.

CVICT03|___|___ **T**

Dimensions in cm: L. 540 | D. 540 | H. 314
 Net weight: 18 Kg

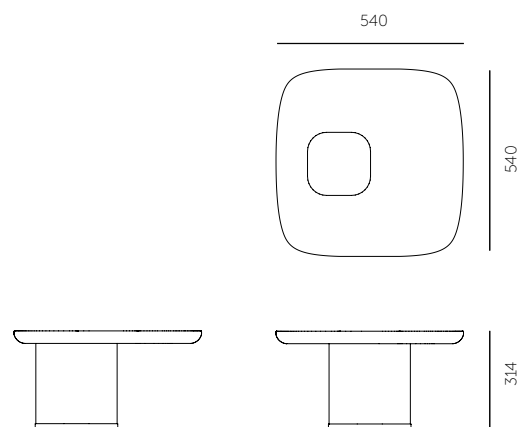

Tavolino *Coffee Table*

Coffee table in **CIMENTO®**. Disponibile in diverse colorazioni.
Coffee table in CIMENTO®. Available in different colors.

CVICT04|___|___ **T**

Dimensions in cm: L. 670 | D. 540 | H. 364
 Net weight: 19 Kg

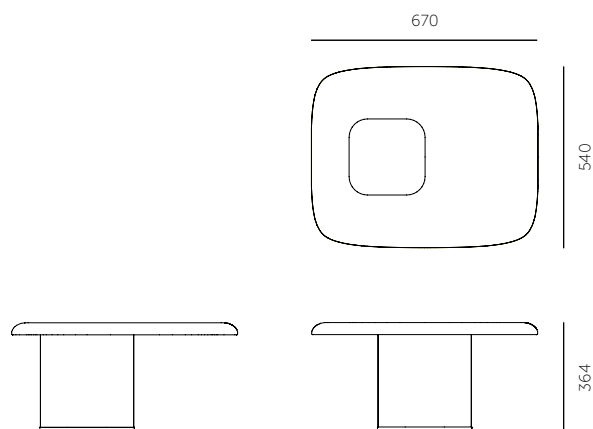

Sedia a dondolo *Rocking chair*

Sedia a dondolo in **CIMENTO®**.
Rocking chair in CIMENTO®.

CBURC01|_____

Dimensions in cm: L. 496 | D. 706 | H. 642
Net weight: 14 Kg

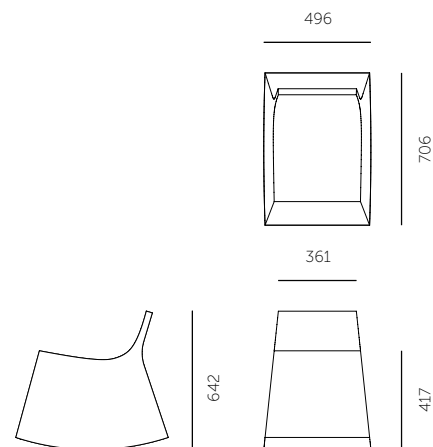

Sedia a dondolo *Rocking chair*

Sedia a dondolo in **CIMENTO®**.
Rocking chair in CIMENTO®.

CBURC02|_____

Dimensions in cm: L. 345 | D. 476 | H. 432
Net weight: 6 Kg

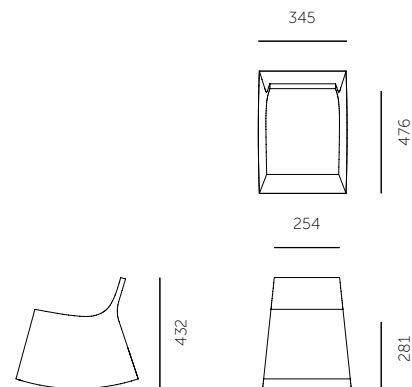

ILLUSTRATED GUIDE

CIMENTO

TORCELLO Defne Koz & Marco Susani

P. 28-39

Sedia *Chair*

Sedia in **CIMENTO®**.
Chair in **CIMENTO®**.

CTOCHO1|_____

Dimensions in cm: L. 455 | D. 555 | H. 720
Net weight: 17 Kg

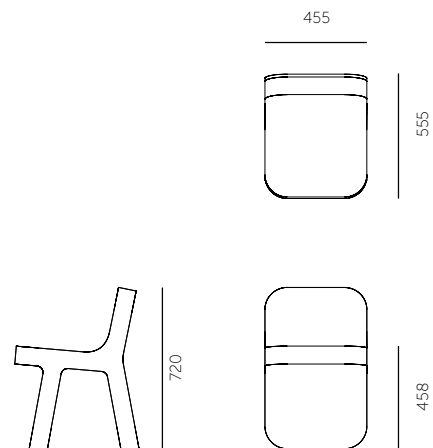

Poltrona *Lounge chair*

Poltrona in **CIMENTO®**.
Lounge chair in **CIMENTO®**.

CTOLC01|_____

Dimensions in cm: L. 697 | D. 703 | H. 720
Net weight: 26 Kg

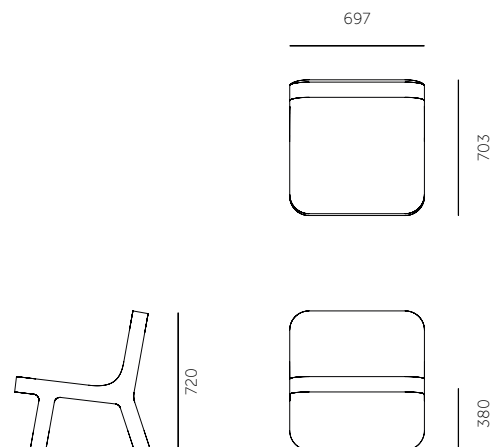

Panca *Bench*

Panca in **CIMENTO®**.
Bench in **CIMENTO®**.

CTOBE01|_____

Dimensions in cm: L. 2000 | D. 703 | H. 720
Net weight: 68 Kg

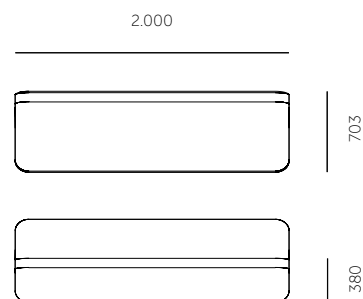
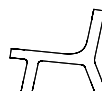

LIDO Parisotto + Formenton

Panca *Bench*

Panca in **CIMENTO®**.
Bench in **CIMENTO®**.

CLIBE01|_____ **T**

Dimensions in cm: L. 1800 | D. 350 | H. 720
Net weight: 40 Kg

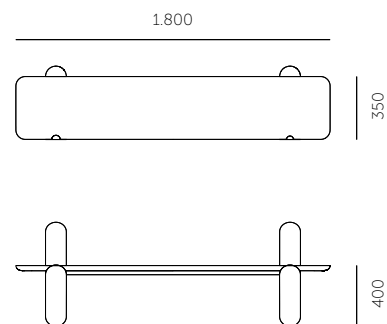
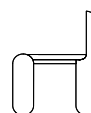

ILLUSTRATED GUIDE

CIMENTO

TRONCHETTO Parisotto + Formenton

P. 50-61

Sgabello *Stool*

Sgabello in **CIMENTO®**. Disponibile in diverse colorazioni.
Stool in CIMENTO®. Available in different colors.

CTRST01|_____

Dimensions in cm: L. 350 | D. 350 | H. 450
 Net weight: 10 Kg

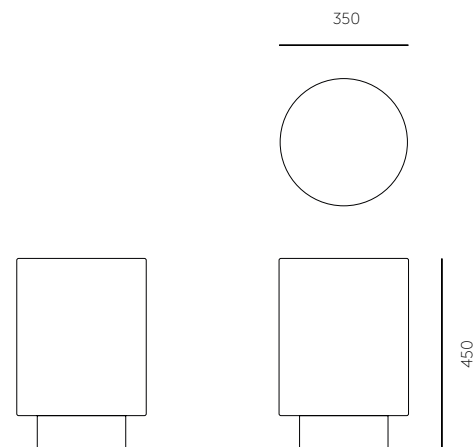

Tavolino *Coffee table*

Tavolino in **CIMENTO®**. Disponibile in diverse colorazioni.
Coffee table in CIMENTO®. Available in different colors.

CTRCT01|_____

Dimensions in cm: L. 800 | D. 800 | H. 350
 Net weight: 28 Kg

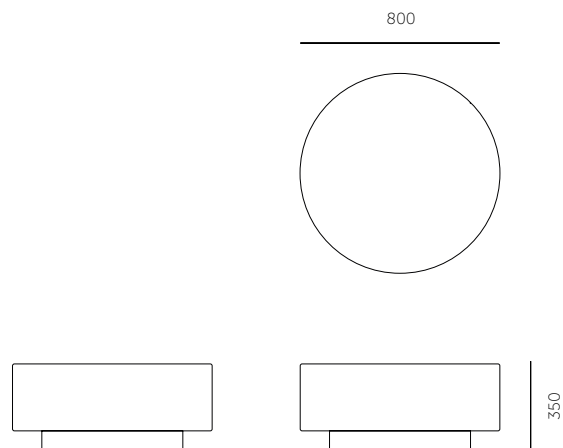

ZITELLA Parisotto + Formenton

P. 62-79

Sgabello *Stool*

Sgabello in **CIMENTO®**. Disponibile in diverse colorazioni.
Stool in CIMENTO®. Available in different colors.

CZIST01|____ **T**

Dimensions in cm: L. 380 | D. 380 | H. 450
Net weight: 16 Kg

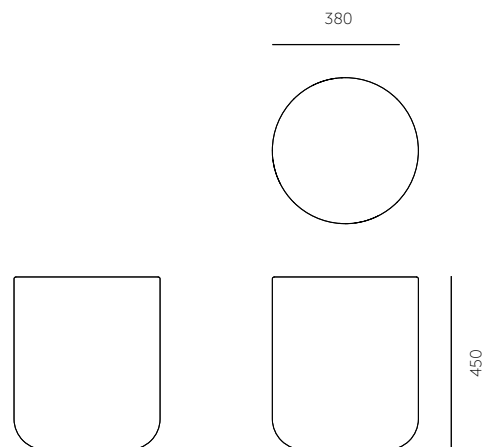

LIDO Parisotto + Formenton

Tavolino *Coffee table*

Tavolino in **CIMENTO®**. Disponibile in diverse colorazioni.
Coffee table in CIMENTO®. Available in different colors.

CZICT01|____ **T**

Dimensions in cm: L. 800 | D. 800 | H. 350
Net weight: 37 Kg

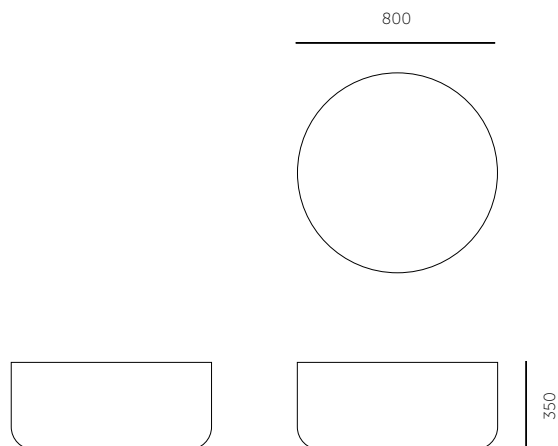

ILLUSTRATED GUIDE

CIMENTO

ACCADEMIA Massimo Dei \ Studio 63

P. 80-97

Contenitori *Storage system*

Contenitore modulare, con elementi verticali in **CIMENTO®** e orizzontali in essenza.
Accessori in essenza oppure laccati.

*Modular storage with vertical elements in CIMENTO® and wood horizontal elements.
Accessories available in wood or lacquered.*

CACCA01|_|_|_|

Dimensions in cm: L. 1600 | D. 380 | H. 630
Net weight: 41 Kg

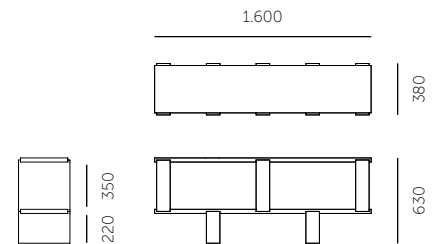
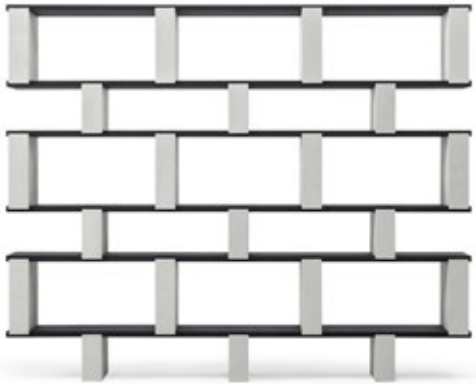

CACCA02|_|_|_|

Dimensions in cm: L. 2335 | D. 380 | H. 630
Net weight: 46 Kg

CACCA03|_|_|_|

Dimensions in cm : L. 1600 | D. 380 | H. 1260
Net weight 59 Kg

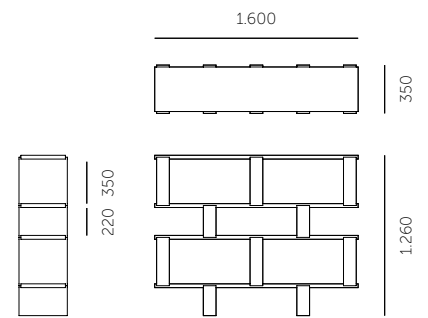
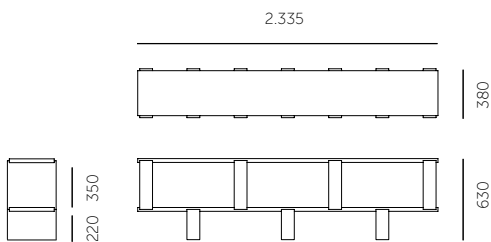

CACCA04|_|_|

Dimensions in cm : L. 1600 | D. 380 | H. 1890
Net weight 102 Kg

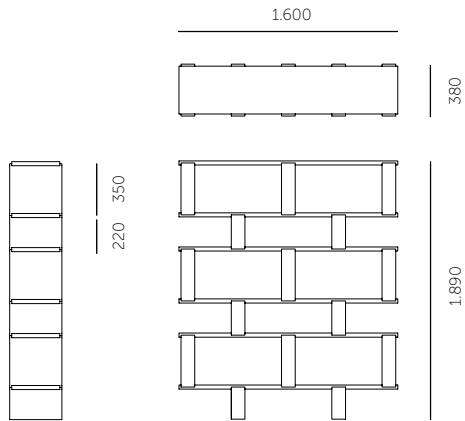

CACCA05|_|_|

Dimensions in cm : L. 2335 | D. 380 | H. 1890
Net weight 138 Kg

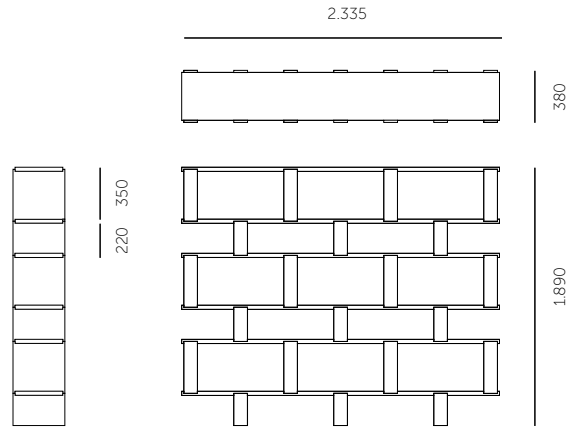

CACCA06|_|_|

Dimensions in cm: L. 3070 | D. 380 | H. 2520
Net weight: 208 Kg

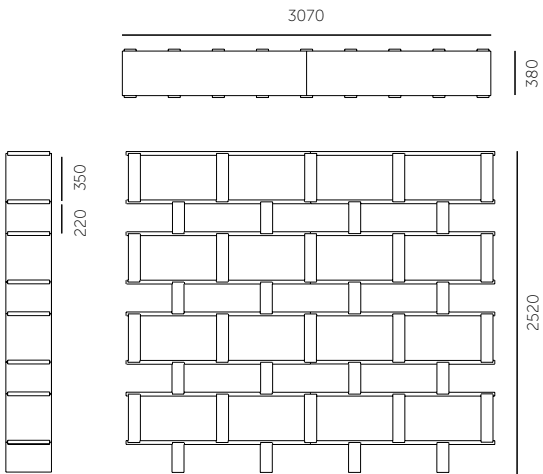

ILLUSTRATED GUIDE CIMENTO

CACCA07|__|__

Dimensions in cm: L. 3805 | D. 380 | H. 2520
Net weight: 232 Kg

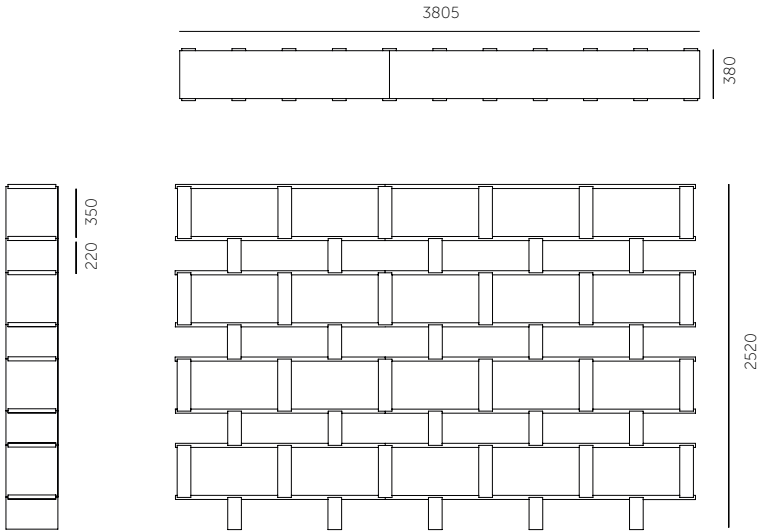

CACCA08|__|__

Dimensions in cm: L. 4540 | D. 380 | H. 2520
Net weight: 256 Kg

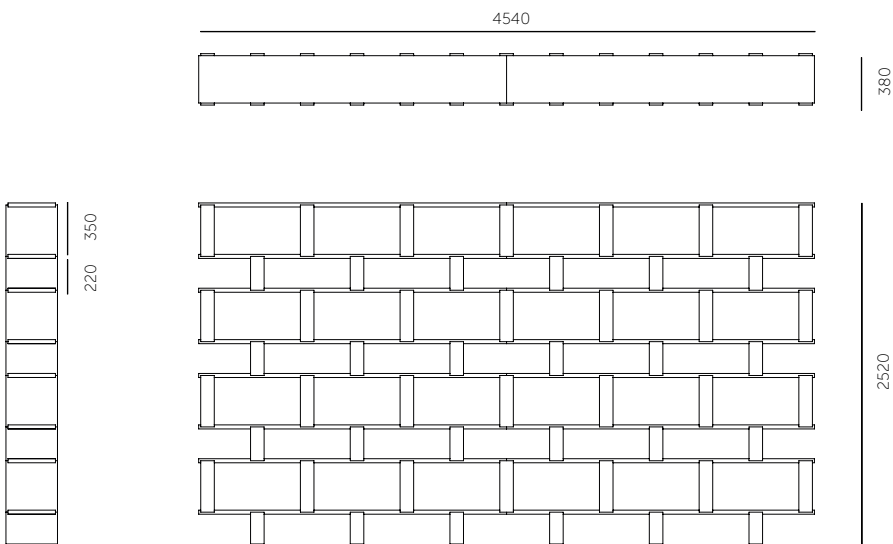

ACCADEMIA

Accessori Accessories

CACBX01**L**|____
CACBX01**E**|____

Dimensions in cm: L. 635 | D. 350 | H. 350
Net weight: 9 Kg

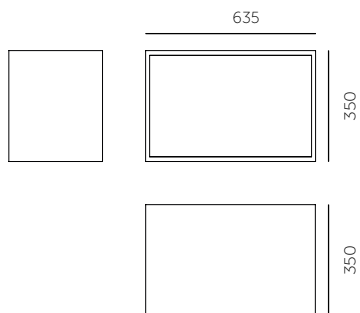

CACBX02**L**|____
CACBX02**E**|____

Dimensions in cm: L. 635 | D. 350 | H. 350
Net weight: 13,5 Kg

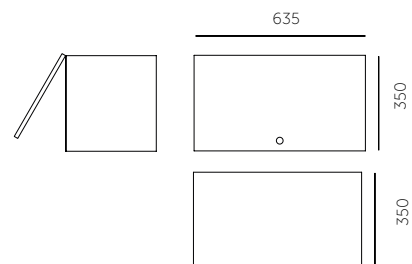

CACBX03**L**|____
CACBX03**E**|____

Dimensions in cm: L. 635 | D. 350 | H. 350
Net weight: 13,5 Kg

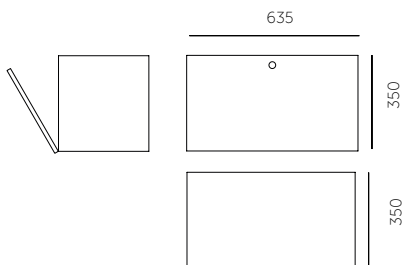

CACBX04**L**|____
CACBX04**E**|____

Dimensions in cm: L. 635 | D. 350 | H. 350
Net weight: 23Kg

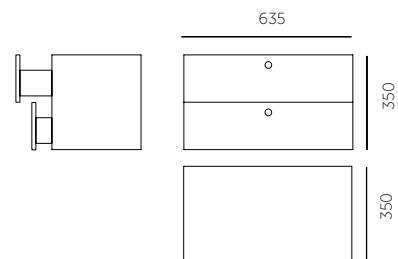

ILLUSTRATED GUIDE

CIMENTO

ACCADEMIA Massimo Dei \ Studio 63

P. 101-107

Tavolo *Table*

Tavolo con gambe in **CIMENTO®** e piano in essenza.
Table with CIMENTO® legs and wooden top

CACTA01|__|__

Dimensions in cm: L. 2000 | D. 1000 | H. 730
 Net weight: 101 Kg

CACTA02|__|__

Dimensions in cm: L. 2500 | D. 1000 | H. 730
 Net weight: 110 Kg

CACTA03|__|__

Dimensions in cm: L. 3000 | D. 1000 | H. 730
 Net weight: 120 Kg

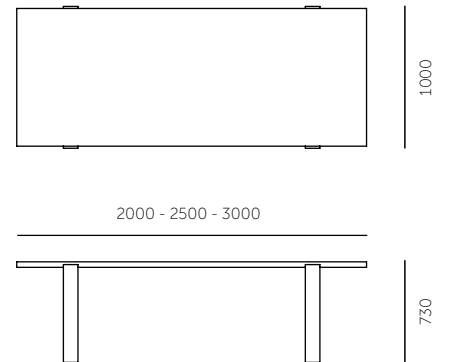

ACCADEMIA Massimo Dei \ Studio 63

Complemento *Complements*

Complemento d'arredo, con elementi verticali in **CIMENTO®** e orizzontali in essenza.
Furniture complement, with vertical elements in CIMENTO® and wood horizontal elements.

CACCM01|_|_|

Dimensions in cm: L. 1600 | D. 380 | H. 410
Net weight: 30 Kg

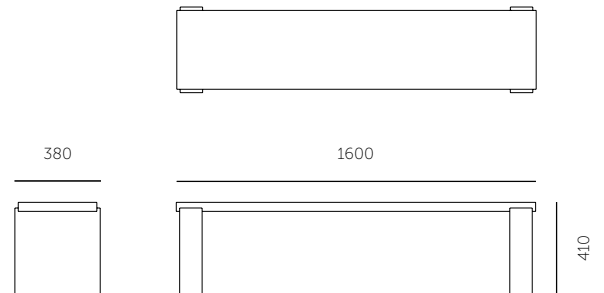

Complemento *Complements*

Complemento d'arredo, con elementi verticali in **CIMENTO®** e orizzontali in essenza.
Furniture complement, with vertical elements in CIMENTO® and wood horizontal elements.

CACCM02|_|_|

Dimensions in cm: L. 2335 | D. 380 | H. 410
Net weight: 40Kg

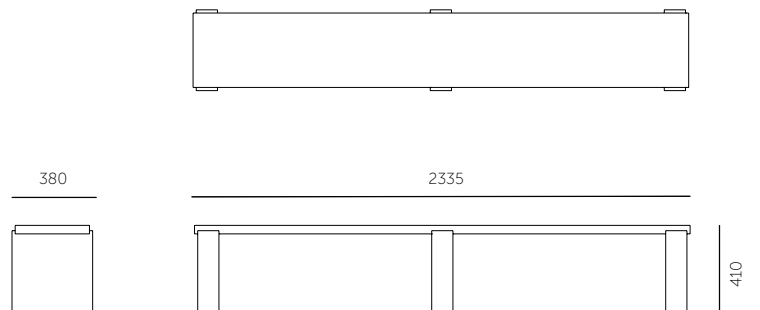

ILLUSTRATED GUIDE

CIMENTO

GIUDECCA Parisotto + Formenton

P. 98-103

Tavolo *Table*

Tavolo in **CIMENTO®**. Disponibile in diverse colorazioni.
 Table in **CIMENTO®**. Available in different colors.

CGITA01|___|___ **T**

Dimensions in cm: L. 1400 | D. 1400 | H. 730
 Net weight: 90Kg

CGITA02|___|___

Dimensions in cm: L. 1600 | D. 1600 | H. 730
 Net weight: 117Kg

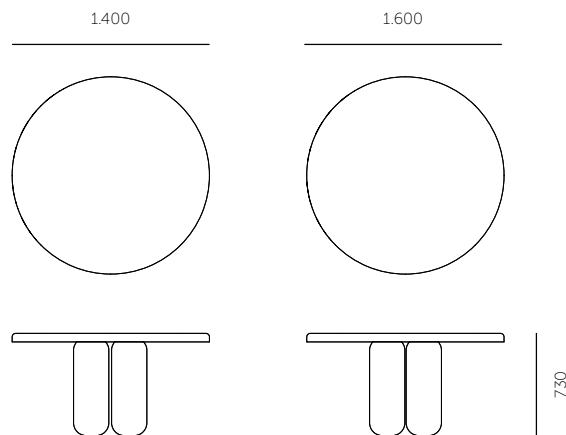

Tavolo *Table*

Tavolo in **CIMENTO®**. Disponibile in diverse colorazioni.
 Table in **CIMENTO®**. Available in different colors.

CGITA03|___|___ **T**

Dimensions in cm: L. 1400 | P. 1400 | H. 730
 Net weight: 124kg

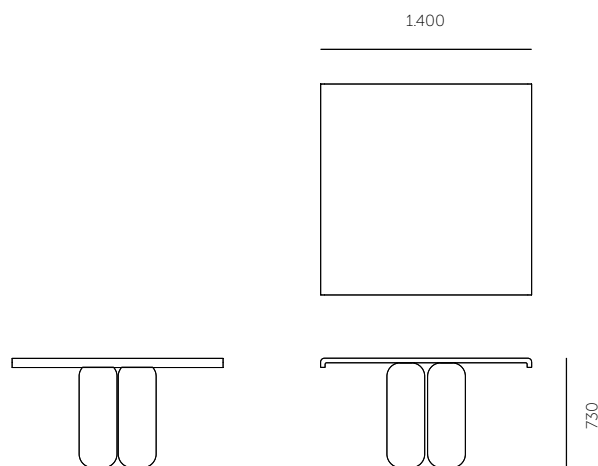

MATERIALS

CIMENTO COLLECTION

COLOURS
CARTELLA COLORI

Colori neutri *Neutral colors*



CL01



CL02

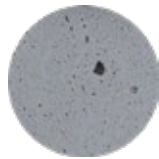

CL04



CL05



CL06



CL10

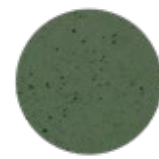

CL20



CL21



CL22



CL26



CL27



CL28



CL32



CL33



CL34



CL38



CL39



CL40



CL44

Cartella colori *Color palette*



CL23



CL24



CL25



CL29



CL30



CL31



CL35



CL36



CL37



CL41



CL42



CL43



BE01



RV01

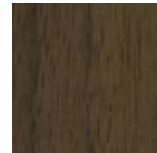

NC01



RV02

Ⓣ FINITURA TONALIZZATA

Trattamento tonalizzante a base di sistemi poliuretani, finalizzato all'omogeneizzazione cromatica delle stuccature con **CIMENTO WILL®**.

L LACCATO PER ACCESSORI

E ESSENZA PER ACCESSORI

I nostri prodotti sono costituiti da materie prime naturali, cementi ed ossidi, per i quali è normale una variazione di tonalità. Il colore della finitura **CIMENTO®** varia tra un lotto e l'altro, ma anche all'interno dello stesso lotto produttivo ci possono essere diverse sfumature. Eventuali differenze di colore sono peculiarità dei prodotti stessi, espressione della loro unicità e irripetibilità.

Ⓣ TONALIZED FINISH

Toning treatment based on polyurethane systems, aimed at the chromatic homogenization of grouting with **CIMENTO WILL®**.

L LACQUERED FOR ACCESSORIES

E ESSENCE FOR ACCESSORIES

CIMENTO® products are made up of natural raw materials, i.e. cement, stones and oxides, whose tonality are naturally variable, for this reason panels can have different colours shadows even in the same production batch; a tone difference needs to be taken in consideration in case of different production batch. Colour variation is a peculiarity of the products themselves, which are unique and not repeatable.

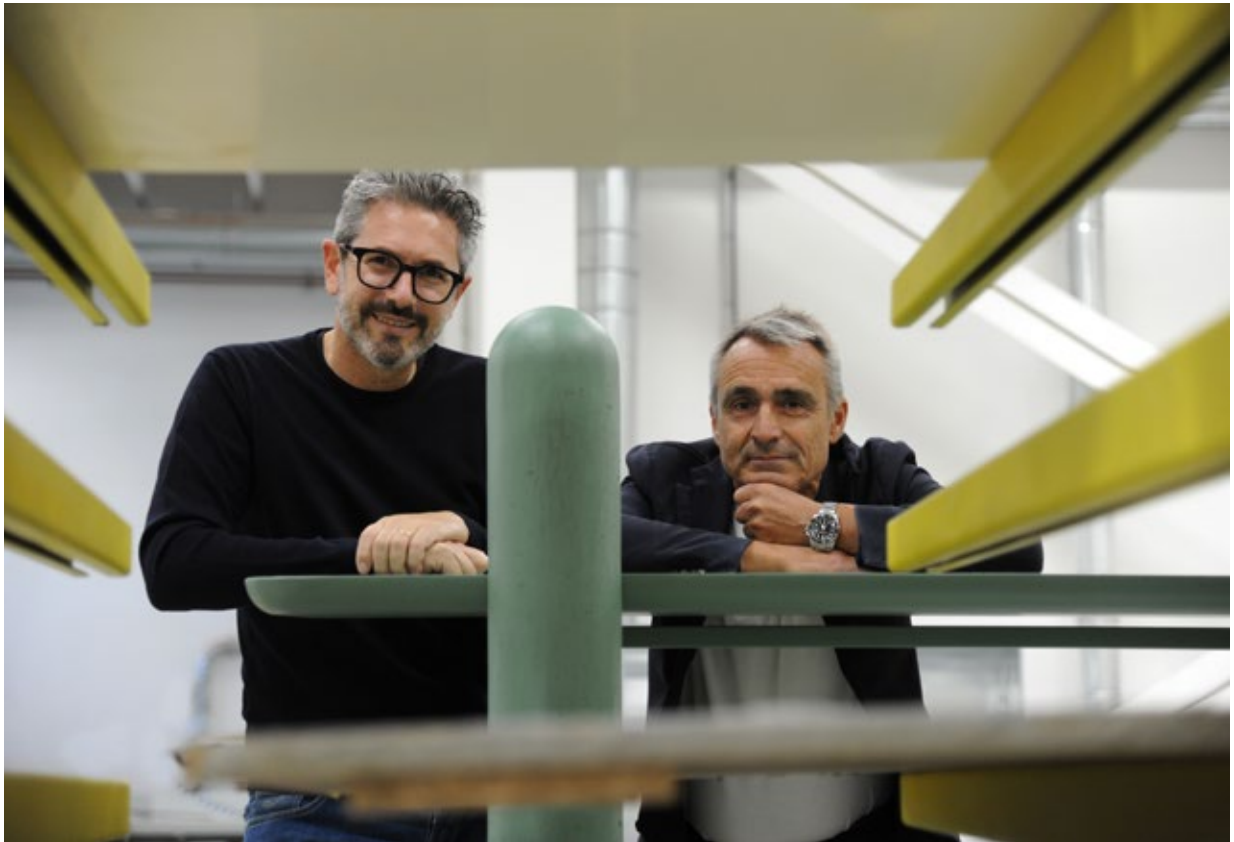

DESIGNERS

La Cimento Collection nasce da una storia unica di intesa e collaborazione tra William Lucchetta e Aldo Parisotto, che si sono incontrati sul terreno comune della passione per la materia e il progetto.

La volontà del fondatore dell'azienda di dare ad uno straordinario materiale come Cimento tutte le possibilità per esprimere al meglio le sue innovative potenzialità dialoga con la visione dell'art director: insieme hanno lavorato dal 2018 per dare voce alle connotazioni estetiche e tecniche della materia attraverso una collezione di arredi e complementi contemporanei, lo studio cromatico di palette suggestive e il coordinamento di una squadra internazionale di designer.

Un'esperienza che mette a frutto know-how artigianale, cura per i dettagli e design di qualità: una storia italiana.

Cimento Collection was born thanks to a unique story that tells about collaboration and synergy between William Lucchetta and Aldo Parisotto that found a common ground in their passion for materials and design.

The founder of the company aimed to find a way to deploy all the potential of innovative Cimento and met Aldo with his open-minded visions about the material. Together they worked to give voice to all the aesthetics and technical connotations of Cimento through a contemporary collection of furniture and complements, a research about suggestive chromatic palettes and the coordination of a team of internationally renowned designers.

This experiences is about artisanal know-how, care for details and high quality design: an Italian story!

DESIGNERS CIMENTO

Parisotto + Formenton



Parisotto + Formenton Architetti è uno studio con sedi a Padova e a Milano fondato nel 1990 da Aldo Parisotto e Massimo Formenton, la cui collaborazione ha origine con l'incontro allo IUAV di Venezia dove entrambi si laureano in Architettura. La loro ricerca progettuale si orienta verso molteplici temi, dall'interior all'architettura, al design e l'art direction, sviluppando una esperienza trentennale, a livello nazionale ed internazionale.

In ambito architettonico si cimentano con realizzazioni museali, commerciali, direzionali e residenziali; in architettura d'interni si specializzano principalmente nel settore retail - dal concept alla realizzazione - con solide collaborazioni con aziende italiane ed internazionali nel campo della moda, del lusso, del food.

Nell'ambito del design realizzano progetti per importanti aziende dell'illuminazione, dell'arredo e della nautica e sul fronte della direzione artistica Parisotto + Formenton lavorano con aziende di rilievo del mercato furniture italiano. Dal 2019 seguono l'art direction di Cimento - coordinandone l'immagine e disegnando la prima collezione di complementi ed arredi per indoor e outdoor, presentata lo stesso anno alla Milano Design Week.

Molteplici sono i progetti in corso da parte dello studio sui temi di urbanizzazione, complessi residenziali e industriali e nel settore dell'ospitalità.

VIGNOLE

TRONCHETTO

Prodotti *Products*

ZITELLA

LIDO

GIUDECCA

Parisotto + Formenton Architetti, with their offices in Padua and Milan, was founded in 1990 by Aldo Parisotto and Massimo Formenton, whose collaboration originates with the meeting at the IUAV in Venice where they both graduate in Architecture. Their design research is oriented towards multiple themes, from interior to architecture, design and art direction: together they achieved a thirty-year experience, nationally and internationally.

In the architectural field, they have experimented with museum, commercial, executive and residential buildings; in interior architecture they have specialized mainly in the retail sector - from concept to realization - through solid collaborations with Italian and international companies in the fashion, luxury, food field.

As regards design, they have carried out projects for important lighting, furniture and yachting companies; as art direction, Parisotto + Formenton work with leading companies in the Italian furniture market. Starting from 2019 they have been following the art direction of CIMENTO® - coordinating its image and designing the first collection of complements and furnishings for indoor and outdoor, which was presented the same year at Milano Design Week.

Many other projects are currently followed by the studio on urbanization issues, residential and industrial complexes and in the hospitality sector.



Massimo Dei gestisce Studio 63, uno studio internazionale di architettura e design che lavora da anni nella progettazione architettonica e nell'interior design con esperienza principalmente nella retail e nell'ospitalità, nonché nella progettazione di prodotti, nella direzione artistica e nella consulenza di design per aziende di arredamento e moda .

Il team è composto da un gruppo di grafici specializzati in diverse discipline che lavorano insieme in uno scambio culturale continuo. Tutto il lavoro svolto è caratterizzato da una forte identità progettuale, frutto di una costante e assidua ricerca e creatività.

Studio 63 opera in oltre 25 paesi in tutto il mondo, occupandosi di progetti in tutti i vari aspetti, dallo sviluppo del concept alla gestione del progetto, con particolare attenzione ai dettagli, alla forma e allo stile.

Progettazione prodotti clienti: ALTRALUCE . ARTEMIDE . BATH & BATH . CIMENTO . OFFICINA CIANI . DANESE . EX. T. . HORM-CASA MANIA . IL FANALE . CAOS . LIP LIGHTING . MARIONI . MISURAEMME . NIC DESIGN . O LUCE . SOFTHOUSE.

Massimo Dei runs Studio 63 is an international architecture and design studio that has been working for years in architectural planning and interior design with experience mainly in retail and hospitality, as well as product design, art-direction and design consulting for furniture and fashion companies.

The team consists of a group of creatives from different disciplines working together in a continuous cultural exchange. All the work that is done is characterized by a strong design identity, the result of constant and assiduous research and creativity.

Studio 63 operates in more than 25 countries around the world, taking care of projects in all its aspects, from concept development to project management, with particular care of details, form and style.

Clients Product Design: ALTRALUCE . ARTEMIDE . BATH & BATH . CIMENTO . OFFICINA CIANI . DANESE . EX. T. . HORM-CASA MANIA . IL FANALE . CAOS . LIP LIGHTING . MARIONI . MISURAEMME . NIC DESIGN . O LUCE . SOFTHOUSE.

DESIGNERS

CIMENTO

Omri Revezs Design



Prodotti *Products*

MURANO

Omri Revezs Design è uno studio multidisciplinare con sede a Venezia. Il lavoro dello studio si focalizza nella convergenza tra umanesimo, tecnologia e pensiero strategico, per così eseguire progetti significativi che spaziano dal design industriale al light design, per poi dedicarsi ad interni, allestimenti e spazi urbani.

Nel 2013, 2015 e 2018 lo studio è stato onorato del prestigioso riconoscimento italiano dell'ADI Design Index e nel 2019 dalla rivista internazionale Wallpaper* per la sua ricerca innovativa, insieme ad altri numerosi premi e riconoscimenti internazionali.

I progetti dello studio sono stati esposti nelle più eminenti vetrine del design internazionale, dal Salone del Mobile a Maison&Object Paris, comprendendo anche La Biennale di Venezia, Triennale di Milano e la Galleria Ben-Simon ed è stato pubblicato in numerose riviste di settore tra cui New Times, Domus e Abitare.

Revezs è un TEDx speaker, insegna attivamente nella facoltà di design dell'università IUAV di Venezia, a ECA European Culture Academy e all'Università Ca' Foscari. Ha guidato workshop in numerose università e preso parte in giurie di concorsi internazionali di design.

Omri Revezs Design is a multidisciplinary design firm based in Venice, Italy. The studio's work is focusing on the union of human sensitivity, technology and strategic thinking, to execute meaningful designs ranging from industrial products and light design, to interiors, exhibitions and urban public spaces.

In 2013, 2015 and 2018 he won the most prestigious Italian Design recognition ADI Design Index and in 2019 the international prestigious award of Wallpaper, among many international design awards for his highly researched, innovative design projects.*

His works have been exhibited in major design platforms such as Salone del Mobile Milan, Maison&Object Paris, Biennale di Venezia, Triennale di Milano, Gallery Ben-Simon and were published in numerous design magazines such as International New Times, Domus, Abitare.

Revezs is a TEDx speaker. He teaches design at the IUAV University of Venice, at ECA European Culture Academy and Ca' Foscari University. He led workshops at various universities and sat on juries for assorted international design competitions.

Defne Koz & Marco Susani



Prodotti *Products*

BURANO

TORCELLO

Defne Koz e Marco Susani sono designer riconosciuti a livello internazionale: basati a Chicago, lavorano insieme da 10 anni, progettando prodotti best-seller, iconici ed emotivamente coinvolgenti per le persone. Defne Koz ha fondato il suo studio di design a Milano dopo essersi formata alla Domus Academy e aver lavorato al fianco di Ettore Sottsass; ha inoltre aperto la strada al design in Turchia ed è oggi tra designer turchi più famosi al mondo.

Marco Susani ha esteso la cultura del design italiano a nuovi campi come Interaction e Strategic Design. Ha iniziato la sua carriera in Olivetti, è stato partner di Ettore Sottsass e ha diretto il Research Center Domus Academy a Milano. Si è poi trasferito negli USA per creare il Motorola Advanced Concept Group e in seguito è stato il vicepresidente globale di Digital Design di Motorola.

Lavorano tra gli altri con Alessi, Apple, Bodum, Enel, FontanaArte, Foscarini, Gaia&Gino, Leucos, Italamp, MIT MediaLab, Mitsubishi, Mobileffe, Motorola, Nestle', Nissan, Panasonic, Pasabahce, Philips, Pirelli, Swarovski, Seiko, TrueDesign, Unilever, Xerox, Vitra, WMF, Zumtobel, 3M.

Defne Koz and Marco Susani are international award-winning designers; based in Chicago, together they have been working together for 10 years designing best-seller products, creating impactful, iconic and emotionally engaging products around humans. Defne Koz studied in Milan and here she started her career with Ettore Sottsass. She also pioneered design in Turkey, becoming one of the most world renowned Turkish designers.

Marco Susani extended the culture of Italian Design to new fields like Interaction Design and Strategic Design. He started his career at Olivetti, he has been partner of Ettore Sottsass, and directed the Research Center Domus Academy in Milan. Then moved to the US to create the Motorola Advanced Concept Group, and later was Motorola's Global Vice President of Digital Design.

Among their client Alessi, Apple, Bodum, Enel, FontanaArte, Foscarini, Gaia&Gino, Leucos, Italamp, MIT MediaLab, Mitsubishi, Mobileffe, Motorola, Nestle', Nissan, Panasonic, Pasabahce, Philips, Pirelli, Swarovski, Seiko, TrueDesign, Unilever, Xerox, Vitra, WMF, Zumtobel, 3M, and others.



Art Director
Aldo Parisotto

Fotografie Photography
Alberto Strada
Invarianti Studio

Styling
Parisotto + Formenton

Graphic Design
Parisotto + Formenton
Cimento - Marketing & Communication Dept.

Print
Grafiche Antiga spa

CONTACTS

HEADQUARTER/SHOWROOM
Via J.F. Kennedy, 107/a - 30027San
Donà di Piave - VE - ITALY

SHOWROOMS

IT
Via Borgogna, 7 - 20122
Milano - ITALY
showroom@cimento.tech
Tel. +39 02 82772692

CH
Piazza Santa Lucia, 7 - 6900
Massagno LUGANO-SWITZERLAND

UK
The Cube Building | 17-21 Wenlock
Road - N1 7GT
LONDON - UNITED KINGDOM

info@cimento.tech



www.cimento.tech



www.cimentocollection.com

Tutte le informazioni contenute in questa brochure sono soggette a cambiamenti. Tutti i diritti sono riservati. Nessuna parte di questa brochure può essere riprodotta senza il nostro permesso scritto.

All the information on this brochure are subject to changes. All rights reserved. Reproduction in whole or in part of the contents of this brochure is prohibited without our written consent.

VOL2 / SEPT 2020

©CIMENTO®



